

# FlexPro<sup>™</sup>

2G - 3G Home or Office Signal Booster Kit

## User Guide

### Versions:

- FlexPro YW - Yagi/Whip Kit
- FlexPro OW - Omni/Whip Kit



Thank you for your purchase of SureCall's FlexPro cellular signal booster kit. FlexPro was specifically designed to eliminate frustrations over dropped calls, limited range and slow data rates by amplifying incoming and outgoing cellular signals in homes and offices up to 2,000 square feet. FlexPro boosts 2G and 3G voice and reception data for all major U.S. carriers.

If you need any assistance while installing this product please contact tech support at 1-888-365-6283 or email us at: [support@surecall.com](mailto:support@surecall.com).

## TABLE OF CONTENTS

<b>How It Works</b> .....	<b>4</b>
<b>Package Contents</b> .....	<b>5</b>
<b>Kitting Information</b> .....	<b>6</b>
<b>Before Installation</b> .....	<b>6</b>
<b>Installation Overview</b> .....	<b>7</b>
<b>FlexPro Installation</b> .....	<b>8</b>
<b>Step 1. Find the area with the Strongest Signal</b> .....	<b>8</b>
<b>Step 2. Install the Outside Antenna</b> .....	<b>9</b>
Antenna Separation.....	9
Step 2a. Installing Outside Omni Antenna .....	10
Step 2b. Installing Outside Yagi Antenna .....	10
<b>Step 3. Install the Signal Booster</b> .....	<b>11</b>
Booster Hardware .....	12
<b>Step 4. Configure Gain Settings</b> .....	<b>12</b>
LED Indicators.....	13
<b>If you Want to Improve Coverage</b> .....	<b>13</b>
<b>Troubleshooting</b> .....	<b>14</b>
<b>Product Specifications</b> .....	<b>15</b>
<b>FCC, IC and Safety Information</b> .....	<b>15</b>
<b>Warranty</b> .....	<b>16</b>
Limitations of Warranty, Damages and Liability .....	17

## HOW IT WORKS

SureCall's FlexPro is a high-quality bidirectional signal booster that enhances cellular signals to areas that are prone to weak cellular coverage.

FlexPro uses two antennas:

- An inside antenna that communicates with your mobile phone.
- An outside antenna that communicates with your carrier's cell tower.

Signals sent from a cell tower are received by the outside antenna, amplified by the booster and then broadcast to your phone via the inside antenna. When your phone transmits, the signal is sent to the inside antenna, amplified and then sent to the cell tower via the outside antenna.

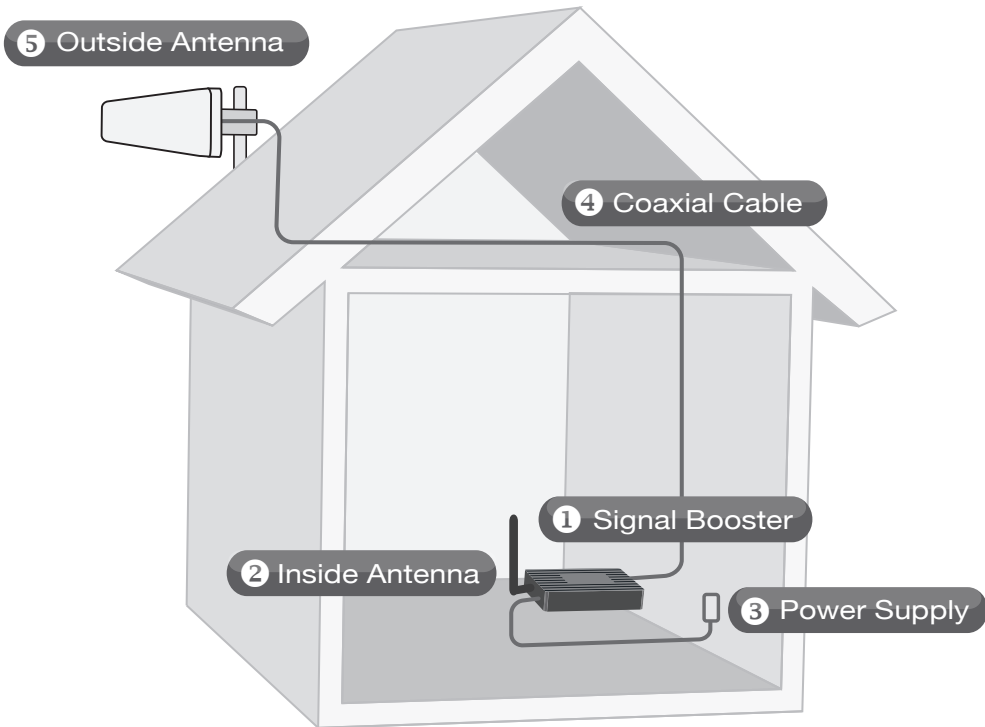

Shown: FlexPro with outside Yagi antenna and inside whip antenna

## PACKAGE CONTENTS

1. Unpack all package contents. For missing or damaged items, contact your reseller.
2. Turn over the signal booster and record the model and serial number for reference:  
Serial #: \_\_\_\_\_  
Purchase Date: \_\_\_\_\_
3. Keep the carton and packing material to store the product in case you need to return. Your FlexPro signal booster package includes the following items:
  - One SureCall FlexPro signal booster
  - One power supply
  - One inside antenna
  - Cable for connecting the outside antenna to the signal booster
  - One outside antenna (Omni OR Yagi)

**FlexPro Signal Booster**



**Power Supply**



**Inside Whip Antenna**



### Outside Antenna Options

**Coax Cable**



**Omni  
Option A.**



**OR**

**Yagi  
Option B.**





**Warning:** Unauthorized antennas, cables, and/or coupling devices are prohibited by FCC new rules. Please contact FCC for details: 1-888-CALL-FCC. Changes or modifications not expressly approved by SureCall could void the user's authority to operate the equipment.

# Before You Install

Note: FlexPro is available in two kits that are customized to your particular needs. Determine which kit you have from the following list:

Package Options	
FlexPro Yagi/Whip Kit	Booster and power supply, outside Yagi antenna, inside omni whip, 50 ft. of RG6 coax cable
FlexPro Omni/Whip Kit	Booster and power supply, outside Yagi antenna, inside omni whip, 50 ft. of RG6 coax cable

## KITTING INFORMATION

	Antenna Type	Model	Use/Coverage	Gain Loss	
				800 MHz Cellular	1900 MHz PCS
	Omni Outside Antenna	SC-289W	The outside omni antenna is ideal for topographies with minimal obstacles, with the ability to communicate in all directions.	3 dBi	4 dBi
	Yagi Outside Antenna	SC-231W	The outside Yagi antenna is ideal for low signal areas. It works best when pointed in the direction of your carrier's cell tower and is capable of reaching towers up to 30 miles away	10 dBi	11 dBi
	Omni Whip Inside Antenna	SC-121W	The inside omni whip antenna connects directly to the booster and is able to send and receive signal in all directions.	3 dBi	3 dBi

**Note:** Due to the recent change of our company name from Cellphone-Mate (CM) to SureCall (SC) we have changed the prefix on all of our antennas, cables and accessories from CM to SC-.

## BEFORE INSTALLATION

1. Make sure you have positioned the booster close enough to an existing electrical outlet.
2. Ensure adequate separation between the planned locations of the inside and outside antennas (see page 11)
3. Make sure you have sufficient cable length between proposed outside antenna location and booster connector.
4. Make sure you have sufficient cable length between proposed inside antenna location and booster connector.

## INSTALLATION OVERVIEW

1. Find the outside area that has the strongest signal (See page 8).
2. Install the outside antenna in the area identified in step 1 (See page 9).
3. Install the inside antenna (See page 11).
4. Mount the signal booster, connect the outside and inside antenna cables to the signal booster, and connect the booster to an AC power source (See page 11).
5. Configure gain settings on the signal booster if needed (See page 12).

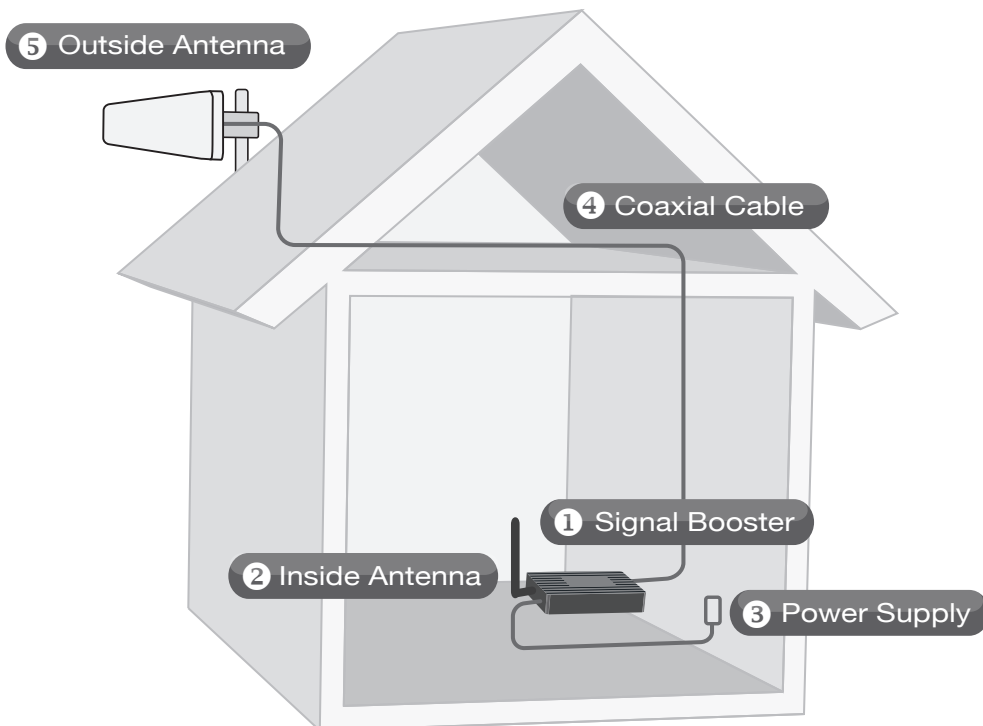

Shown: FlexPro with outside Yagi antenna and inside whip antenna

## FLEXPRO INSTALLATION

### Step 1. Find the area with the Strongest Signal

The signal booster requires a minimum cellular signal of low  $-100$  dBm to high  $-90$  dBm. If your FlexPro Kit includes an outside omni antenna and you can only achieve reception of one bar or less, you may need a FlexPro yagi antenna which is capable of targeting carrier antenna towers that are up to 30 miles away. Call or email SureCall for assistance.

Signal readings usually appear as a negative number (for example,  $-85$ ). The stronger the signal, the closer it gets to zero. Aim for a signal between  $-65$  and  $-85$  dB. Stronger signals may cause the affected frequency bands on the booster to shut down (see the graph below). Before installing the outside antenna, find the area with the strongest cellular signal source from your service provider by following the directions below. You can also go to [www.antennasearch.com](http://www.antennasearch.com) to find the general location of your carrier's towers.

Measure the strength of the existing cellular signal in various locations

- Apple iPhones: Dial\*3001# 12345#\* and press Call. In the top-left corner, a number appears instead of bars.
- Android devices: download apps such as "Network Signal Info" in the Google Play store to measure signal strength. Search check real signal strength to find other cell signal measurement apps.
- Internet: go to [www.speedtest.net](http://www.speedtest.net)

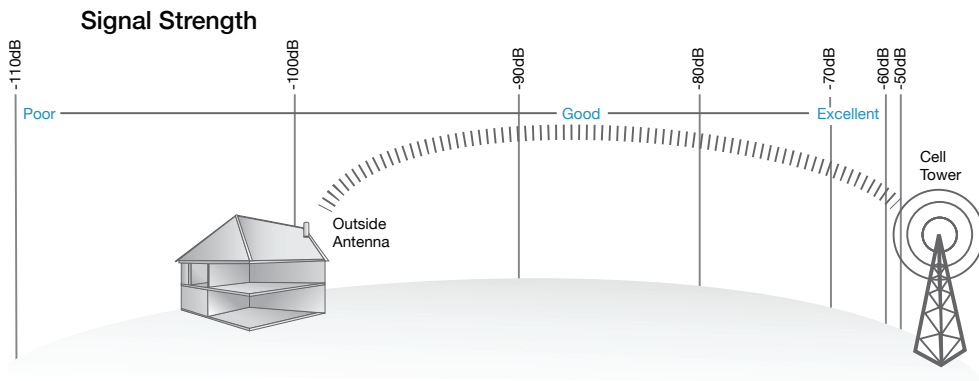

**Note:** Where you install your outside antenna in relation to the carrier's cell phone tower also determines signal strength. Although cell phone carriers try to place towers for maximum coverage, local ordinances and terrain features can restrict tower locations, which can limit signal strength at your location.



## Step 2. Install the Outside Antenna

Your kit includes one of two options for the outside antenna:

**Option A.** Omni antenna: Sends and receives signals in a 360° radius.

**Option B.** Yagi antenna: Directional antenna, works best when pointed in the direction of your cell phone carrier's nearest cell tower.

Mount the outside antenna as high as possible in the area you located the best signal source (see step 1 on the previous page). Make sure that the mounting area has least a 12-inch radius clear of obstructions and other radiating elements. If the mounting area is prone to weak cellular signals or if the density of the roof and ceiling partially block the signal, the booster will operate at its default setting.

Be sure to place the outside antenna in a straight line at least 25 feet from the inside antenna for best performance.

Do not colocate antennas or operate the outside antenna with any other antenna or signal boosters.

Run the cable from the outside antenna to the signal booster. Do not connect the cable to the booster at this time.

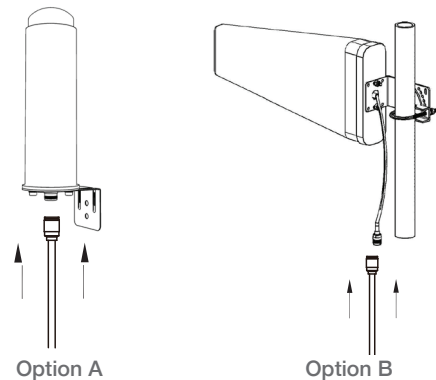

## Antenna Separation

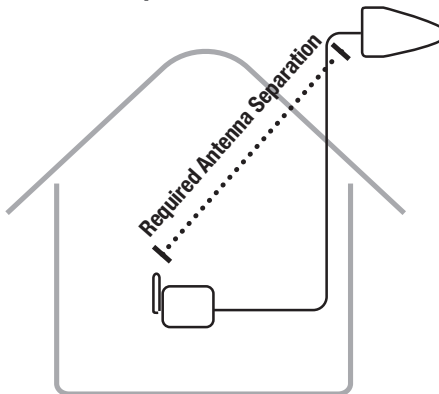

If the Coverage is	And Antenna Separation is	Set All Dials to
1,500 - 2,000 sq. ft.	40 - 60 ft.	55
1,000 - 1,500 sq. ft.	35 - 50 ft.	50
1,000 sq. ft. and below	30 - 35 ft.	45 or below

**Note:** As you can see from the table above, acquiring the recommended indoor and outdoor antenna separation optimizes coverage significantly. Any reduced antenna separation reduces the booster's coverage capabilities.

# Installing Your Hardware

## Step 2a. Installing Outside Omni Antenna

1. Unscrew antenna from L-mounting bracket on antenna base with hands, or wrench, if needed.
2. Using vertical plate of bracket, mark position of desired placement with pencil or marker.
3. Unscrew nut on end of stucco screw and remove it along with lock washer and regular washer.
4. Place vertical plate into desired location and tap the screws, head first, along with sleeve, into stucco 1/2" to 5/8" deep into place.
5. In this order, place washer, lock washer and nut on each screw and tighten until secure. When tightening screw, sleeve will expand to secure plate. Screw antenna securely back onto horizontal plate.

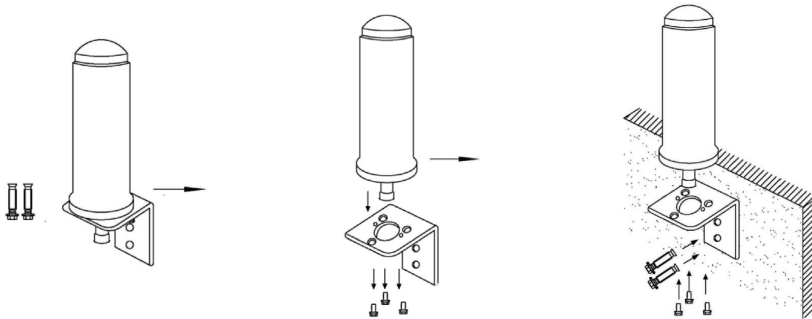
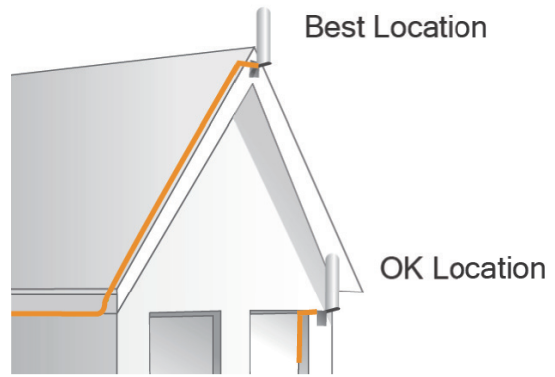

Note: If desired surface for installation plate is wood or concrete, wood or masonry screws for L-plate will have to be purchased separately.

## Step 2b. Installing Outside Yagi Antenna

1. Install U-Bolt on pole.
2. Slide pipe clamp over U-Bolt with the flat side facing away from the pipe.
3. Slide antenna bracket onto U-Bolt in desired location.
4. Install flat washer, split washer and nut, hand tighten.

Note: Antenna may be installed on a variety of pipe angles, ensure that the antenna is pointing in the direction of the closest cellular tower and is vertical with the drip hole at the bottom. To find the location of the closest cell tower go to: [www.cellreception.com](http://www.cellreception.com).

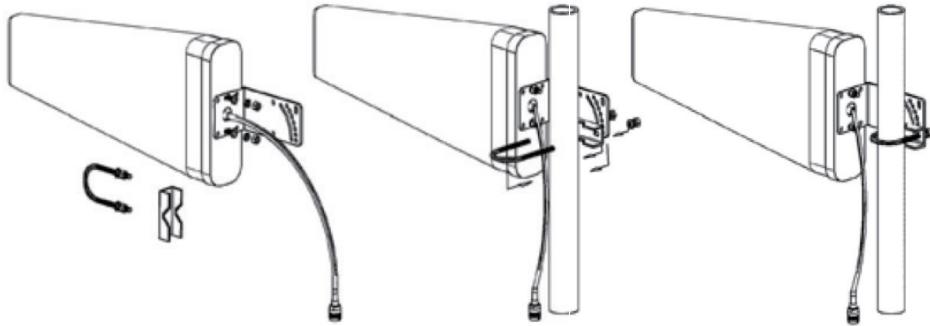

## Step 3. Install the Signal Booster

1. Connect the inside antenna to the booster by screwing it directly into the port of the booster labeled “INSIDE”.
2. Select a location for the booster that is close to a working AC outlet\*. Because the supplied inside antenna is omni-directional (i.e. it delivers signal in a 360° radius), the booster should be placed in a central location with the antenna oriented in an upright position. Do not expose the signal booster to excessive heat, direct sunlight, moisture, and airtight enclosures. In areas where there are higher temperatures, install the booster vertically, so air can move between the metal channels on the faceplate.

Note: Should you choose to mount the booster to a wall, screws have been provided. Use the supplied screws or appropriate screws for surface of mounting location and drill through screw tab holes on booster (see “FlexPro Booster Assembly” on page 12).

3. Connect the remaining end of the RG6 coax cable to the booster port marked “OUTSIDE” and hand-tighten the connection.
4. Connect the AC power cord to the booster and plug into a 110V AC power outlet. Once the booster has been completely assembled and in desired location, turn the booster’s power switch on.
  - The **Power** LED lights up to show that the signal booster is ready for use (see “LED Indicators” on page 13).
  - The **Alert** LEDs flash 5 times on each band to show the band is activated.

**Note:** If the Power LED does not turn ON or the Alert LEDs continue to flash, see “Troubleshooting” on page 14. This booster is rated for 5-15V input voltage. DO NOT use the booster with a higher voltage power supply. This can damage the booster, cause personal injury and void your warranty.

# Installing Your Hardware

## Booster Hardware

The following image shows the key hardware components on the cellular booster. Refer to this image as you install your FlexPro kit components.

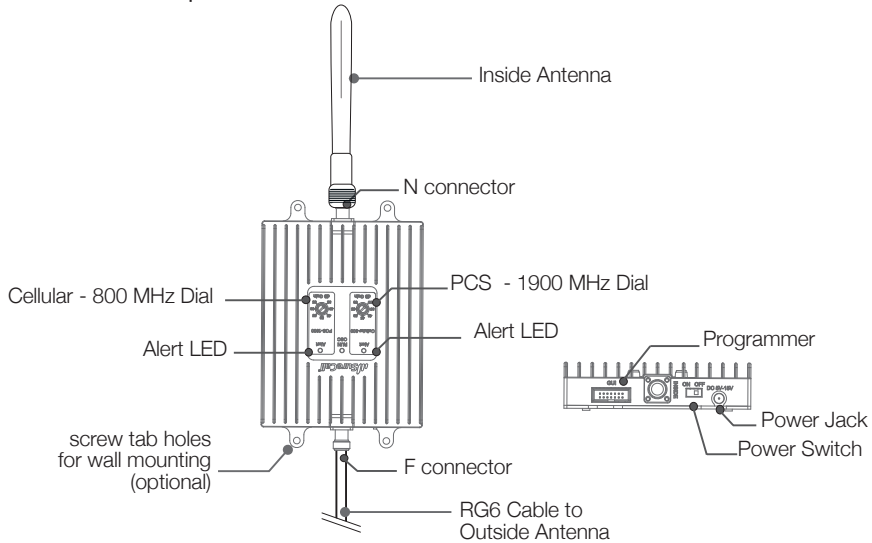

FlexPro Booster Assembly

## Step 4. Configure Gain Settings

1. Find the PCS and Cellular on the top of the signal booster.
2. Set the dials according to the coverage area and the distance between the indoor and outdoor antennas.

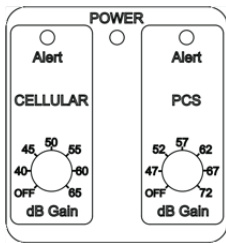

If the Coverage is	And Antenna Separation is	Set All Dials to
1,500 - 2,000 sq. ft.	40 - 60 ft.	55
1,000 - 1,500 sq. ft.	35 - 50 ft.	50
1,000 sq. ft. and below	30 - 35 ft.	45 or below

**Note:** As you can see from the table above, acquiring the recommended indoor and outdoor antenna separation optimizes coverage significantly. Any reduced antenna separation reduces the booster's cellular signal capabilities.

## LED INDICATORS

LED Color	LED Condition	Indication
Red	Solid	Band is off. If a red light has been flashing for an extended time, the band will automatically shut off and display a solid red light. This can also happen when the booster attenuation has been turned all the way down.
Red	Flashing	Indicates that the booster is receiving too much signal which could cause the affected band to automatically turn off. When this happens: <ol style="list-style-type: none"> <li>For kits using an OMNI outside antenna, relocate the outside antenna to a location where the signal is weaker.</li> <li>For kits using a YAGI outside antenna, turn the antenna in short increments away from the signal source.</li> <li>Add an inline attenuator to the cable coming into the outside port of the booster.</li> </ol>
Yellow	Flashing	Indicates that the Automatic Gain Control (AGC) is self-adjusting. This is part of normal operation.
Yellow	Solid	Indicates that the band is inactive. Light is off while band is active.
Yellow/Red	Alternately Flashing	Oscillation is detected. First, try increasing the separation between the inside and outside antennas. If oscillation continues, lower the dB gain in small increments until the light turns off or flashes yellow. If your booster kit uses two directional antennas (example: outside Yagi antenna and inside panel antenna), ensure that they are facing away from one another.

## IF YOU WANT TO IMPROVE COVERAGE

- Find a location that receives a stronger signal and relocate the outside antenna to that location.
- Increase the distance between the outside and inside antennas.
- Turn each dial on your booster to maximum gain.

**Warning:** Do not adjust the uplink and downlink dB attenuation settings more than 20dB, this could cause the affected frequency bands in the booster to shut down.

## TROUBLESHOOTING

In the event you encounter a problem, follow the suggestions below to resolve the issue.

To resolve issues indicated by the LEDs, refer to “LED Indicators” on page 13.

Problem	Resolution
Signal booster has no power	<p>Verify that the power switch on the booster is turned on.</p> <p>Verify that the power source is not controlled by a switch that can remove power from the outlet by connecting to an alternate power source.</p> <p>If available, use testing equipment like a multimeter to determine the voltage output of the power supply. It should match the stated output on the AC adapter.</p> <p>Check the green POWER LED on the signal booster. If it is OFF while the power switch is on and the AC adapter and outlet is in working order, contact tech support at:</p> <p>1-888-365-6283 or support@surecall.com, or go to www.surecall.com and log on to online support to receive an RMA.</p>
After installing your signal booster system, you have no signal or reception	<p>Verify that all cable connections are tightly secured.</p> <p>On the booster, verify that there are no FLASHING or SOLID RED LEDs, or lights rapidly FLASHING between two colors.</p> <p>Ensure that the signal booster’s dB gain is at maximum setting on each dial.</p>

## PRODUCT SPECIFICATIONS

FlexPro Specifications	
Uplink Frequency Range (MHz):	824-849 / 1850-1910
Downlink Frequency Range (MHz):	869-894 / 1930-1990
Input Impedance:	50 $\Omega$
Maximum Gain:	65 dB Cellular / 72 dB PCS
Noise Figure:	7 dB
Supported Standards:	CDMA, WCDMA, GSM, EDGE, HSPA+, EVDO and all cellular standards
AC Input:	5-15V
Maximum Output Power:	1 Watt EIRP
Cable:	RG6
RF Connectors:	N Female (both ends)
Power Consumption:	<10W
Operation Temperature:	-4° to +158° F
Dimensions:	8" x 1.25" x 5"
Weight:	1 Lb 8 oz
FCC ID / IC:	RSNFLEXPRO / 7784A-FLEXPRO

## FCC, IC AND SAFETY INFORMATION

This is a CONSUMER device.

BEFORE USE, you MUST REGISTER THIS DEVICE with your wireless provider and have your provider's consent. Most wireless providers consent to the use of signal boosters. Some providers may not consent to the use of this device on their network. If you are unsure, contact your provider.

You MUST operate this device with approved antennas and cables as specified by the manufacturer. Antennas MUST be installed at least 20 cm (8 inches) from any person. You MUST cease operating this device immediately if requested by the FCC or a licensed wireless service provider.

**WARNING: E911 location information may not be provided or may be inaccurate for calls served BY USING THIS DEVICE.**

Note: This equipment has been tested and found to comply with the limits for a Class B digital device, pursuant to part 15 of the FCC Rules. These limits are designed to provide reasonable protection against harmful interference in a residential installation. This equipment generates, uses and can radiate radio frequency energy and, if not installed and used in accordance with the instructions, may cause harmful interference to radio communications. However, there is no guarantee that interference will not occur in a particular installation. If this equipment does cause harmful interference to radio or television reception, which can be determined by turning the equipment off and on, the user is encouraged to try to correct the interference by one or more of the following measures:

- Reorient or relocate the receiving antenna.
- Increase the separation between the equipment and receiver.
- Connect the equipment into an outlet on a circuit different from that to which the receiver is connected.
- Consult the dealer or an experienced radio/TV technician for help.

The Manufacturer's rated output power of this equipment is for single carrier operation. For situations when multiple carrier signals are present, the rating would have to be reduced by 3.5 dB, especially where the output signal is re-radiated and can cause interference to adjacent band users. This power reduction is to be by means of input power or gain reduction and not by an attenuator at the output of the device.

La puissance de sortie nominale indiquée par le fabricant pour cet appareil concerne son fonctionnement avec porteuse unique. Pour des appareils avec porteuses multiples, on doit réduire la valeur nominale de 3,5 dB, surtout si le signal de sortie est retransmis et qu'il peut causer du brouillage aux utilisateurs de bandes adjacentes. Une telle réduction doit porter sur la puissance d'entrée ou sur le gain, et ne doit pas se faire au moyen d'un atténuateur raccordé à la sortie du dispositif.

## WARRANTY

### Three-Year Product Warranty

SureCall warrants its products for three years from the date of purchase against defects in workmanship and/or materials. Specifications are subject to change. The three-year warranty only applies to products meeting the latest FCC Certification Guidelines stated on 2/20/2013 and going into effect April 30, 2014. A two-year warranty applies to any products manufactured before May 1, 2014.

Products returned by customers must be in their original, un-modified condition, shipped in the original or protective packaging with proof-of-purchase documentation enclosed, and a Return Merchandise Authorization (RMA) number printed clearly on the outside of the shipping container.

Buyers may obtain an RMA number for warranty returns by calling the SureCall Return Department toll-free at 1-888-365-6283. Any returns received by SureCall without an RMA number clearly printed on the outside of the shipping container will be returned to sender. In order to receive full credit for signal boosters, all accessories originally included in the signal booster box must be returned with the signal booster. (The Buyer does not need to include accessories sold in addition to the signal booster, such as antennas or cables.)

This warranty does not apply to any product determined by SureCall to have been subjected to misuse, abuse, neglect, or mishandling that alters or damages the product's physical or electronic properties.

SureCall warrants to the Buyer that each of its products, when shipped, will be free from defects in material and workmanship, and will perform in full accordance with applicable specifications. The limit of liability under this warranty is, at SureCall's option, to repair or replace any product or part thereof which was purchased up to **THREE YEARS after May 1, 2014 or TWO YEARS for products purchased before May 1, 2014**, as determined by examination by SureCall, prove defective in material and/or workmanship. Warranty returns must first be authorized in writing by SureCall. Disassembly of any SureCall product by anyone other than an authorized representative of SureCall voids this warranty in its entirety. SureCall reserves the right to make changes in any of its products without incurring any obligation to make the same changes on previously delivered products.

As a condition to the warranties provided for herein, the Buyer will prepay the shipping charges for all products returned to SureCall for repair, and SureCall will pay the return shipping with the exception of products returned from outside the United States, in which case the Buyer will pay the shipping charges.

The Buyer will pay the cost of inspecting and testing any goods returned under the warranty or otherwise, which are found to meet the applicable specifications or which are not defective or not covered by this warranty.

Products sold by SureCall shall not be considered defective or non-conforming to the Buyer's order if they satisfactorily fulfill the performance requirements that were published in the product specification literature, or in accordance with samples provided by SureCall. This warranty shall not apply to any products or parts thereof which have been subject to accident, negligence, alteration, abuse, or misuse. SureCall makes no warranty whatsoever in respect to accessories or parts not supplied by it.



## Limitations of Warranty, Damages and Liability

EXCEPT AS EXPRESSLY SET FORTH HEREIN, THERE ARE NO WARRANTIES, CONDITIONS, GUARANTEES, OR REPRESENTATIONS AS TO MERCHANTABILITY, FITNESS FOR A PARTICULAR PURPOSE, OR OTHER WARRANTIES, CONDITIONS, GUARANTEES, OR REPRESENTATIONS, WHETHER EXPRESSED OR IMPLIED, IN LAW OR IN FACT, ORAL OR IN WRITING.

SURECALL AGGREGATE LIABILITY IN DAMAGES OR OTHERWISE SHALL NOT EXCEED THE PAYMENT, IF ANY, RECEIVED BY CELL-PHONE-MATE, INC. FOR THE UNIT OF PRODUCT OR SERVICE FURNISHED OR TO BE FURNISHED, AS THE CASE MAY BE, WHICH IS THE SUBJECT OF CLAIM OR DISPUTE. IN NO EVENT SHALL SURECALL BE LIABLE FOR INCIDENTAL, CONSEQUENTIAL, OR SPECIAL DAMAGES, HOWSOEVER CAUSED.

All matters regarding this warranty shall be interpreted in accordance with the laws of the State of California, and any controversy that cannot be settled directly shall be settled by arbitration in California in accordance with the rules then prevailing of the American Arbitration Association, and judgment upon the award rendered may be entered in any court having jurisdiction thereof. If one or more provisions provided herein are held to be invalid or unenforceable under applicable law, then such provision shall be ineffective and excluded to the extent of such invalidity or unenforceability without affecting in any way the remaining provisions hereof.

48346 Milmont Drive  
Fremont, California 94538  
USA  
888.365.6283  
Fax: 510.996.7250  
[www.surecall.com](http://www.surecall.com)

SureCall has made a good faith effort to ensure the accuracy of the information in this document and disclaims the implied warranties of merchantability and fitness for a particular purpose and makes no express warranties, except as may be stated in its written agreement with and for its customers. SureCall shall not be held liable to anyone for any indirect, special or consequential damages due to omissions or errors. The information and specifications in this document are subject to change without notice. © 2014. All Rights Reserved. All trademarks and registered trademarks are the property of their respective owners.

This is a **CONSUMER** device.

**BEFORE USE, you MUST REGISTER THIS DEVICE** with your wireless provider and have your provider's consent. Most wireless providers consent to the use of signal boosters. Some providers may not consent to the use of this device on their network. If you are unsure, contact your provider.

You **MUST** operate this device with approved antennas and cables as specified by the manufacturer. Antennas **MUST** be installed at least 20 cm (8 inches) from any person. You **MUST** cease operating this device immediately if requested by the FCC or a licensed wireless service provider.

**WARNING.** E911 location information may not be provided or may be inaccurate for calls served by using this device.

Note: This equipment has been tested and found to comply with the limits for a Class B digital device, pursuant to part 15 of the FCC Rules. These limits are designed to provide reasonable protection against harmful interference in a residential installation. This equipment generates, uses and can radiate radio frequency energy and, if not installed and used in accordance with the instructions, may cause harmful interference to radio communications. However, there is no guarantee that interference will not occur in a particular installation. If this equipment does cause harmful interference to radio or television reception, which can be determined by turning the equipment off and on, the user is encouraged to try to correct the interference by one or more of the following measures:

- Reorient or relocate the receiving antenna.
- Increase the separation between the equipment and receiver.
- Connect the equipment into an outlet on a circuit different from that to which the receiver is connected.
- Consult the dealer or an experienced radio/TV technician for help.